

Single-Column Pantograph Disconnectors Type TFB 123 – 550 kV

for Outdoor Installation

Publication No. 1HPL 700 004 En



HAPAM

Application

Disconnectors are used for metallic isolation of systems by creating in the open position a visible isolating distance.

They are appropriate for switching small currents or currents when no significant change in voltage occurs across the terminals.

Single-column pantograph disconnector type TFB is appropriate for outdoor installations with conductors arranged at two different levels. They permit modern installation design and do not require much area.

Optionally each disconnector pole can be equipped with an earthing switch for earthing and short-circuiting disconnected sections of the substation or plant.

Regulations

The TFB disconnectors comply with publication IEC 62271-102; IEC 60694 and most other national regulations. They are available for rated voltages from 170 to 550 kV.

Tests

The type tests on the disconnectors type TFB were performed successfully in our own and also in independent test laboratories in accordance with the latest regulations. During manufacture all components are continuously subjected to quality tests in order to ensure consistent high quality of the products.

After completion of the disconnector poles, comprehensive electrical and mechanical routine tests are carried out on the poles and associated operating mechanisms so that their perfect functioning is guaranteed.

Features

- **Especially suitable for plant with minimal installation area.**
- **Switching position clearly recognisable from a far distance.**
- **High dynamic force thanks to suitable dimensioning of the pantograph and the attached damper**
- **Reliable opening and closing even when disconnector is covered with ice**
- **Wide catching range.**
- **Short assembly time.**
- **Easy adjustment thanks to the stud-bolt arrangement.**
- **Available connections for all busbar designs.**
- **Highest possible degree of operating safety and maintenance-free operating due to the welded pantograph construction.**
- **Especially suitable for outdoor installation due to the use of aluminium or galvanised steel parts.**
- **Positive switching positions due to dead centre interlock**

Design

The stable frame is carrying constructional element of the disconnecter. It is mounted to the foundation by means of four (3) studs and supports the support insulator (4) with intermediate piece (6), gear box (7), and the pantograph (8), as well as the pivot bearing (9) with the rotary insulator (5) and -if available -the built-in earthing switch (10) with its pivot bearing (12).

The top intermediate piece (6) is arranged between the support insulator (4) and the gear box (7) with the pantograph (8). It also serves as mounting point for the bottom conductor; the cables or tubes can run laterally past the switch in piece (fig.6). Adaptation of the top intermediate piece to the respective installation needs (e.g. equipment with 2 or 4 cable pulleys for straining of the cable bus bars, see fig.7) helps to reduce the number of structural elements and thus the work involved in mounting. In the case of disconnecters with built-on earthing switches, the earthing switch contact is attached to the top intermediate piece (fig.2).

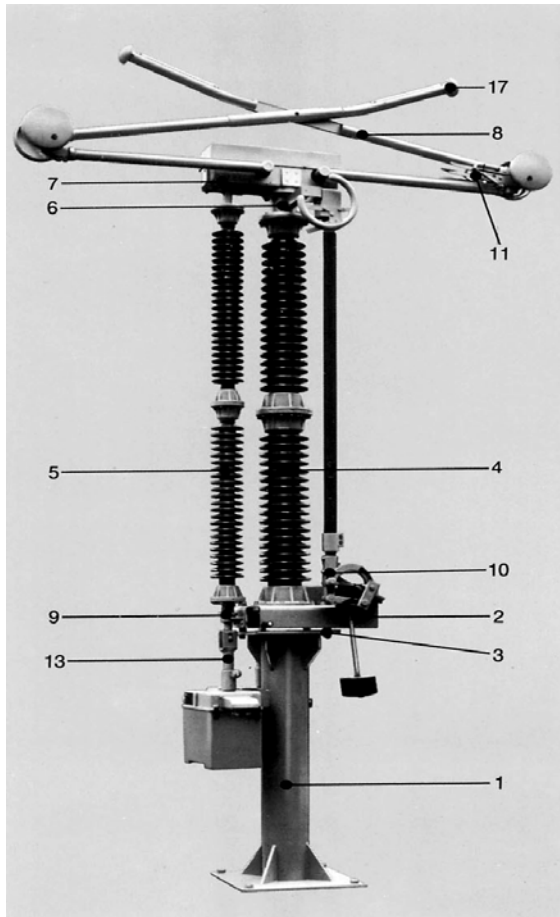

1. Pole of pantograph disconnecter TFB 245 with built in earthing switch type TEB

- 1 – foundation (not in scope of delivery)
- 4 – support insulator; 5 – rotary insulator
- 6 – intermediate piece 7 – gear box
- 8 – pantograph 10 – earthing switch
- 11 – damper 17 – corona protection fitting

The pantograph has the welded aluminium construction and together with the cast aluminium gearbox forms a mechanical unit. The construction guarantees the highest possible degree of mechanical stability and reliable current transfer especially in case of the short circuit. Bolt connections are generally avoided so that operating reliability is not impaired with time due to the bolts working loose or by corrosion in the joint.

For balancing the weight of the pantograph in the gearbox is mounted a counterbalance spring.

Because gearbox is closed on all sides the installed components are protected against atmospheric influences, contamination and animals (e.g. birds, snakes) as well as their nests. On all four sides are provided flat terminals offering universal connection possibilities. The entire transmission system has a simple mechanical design.

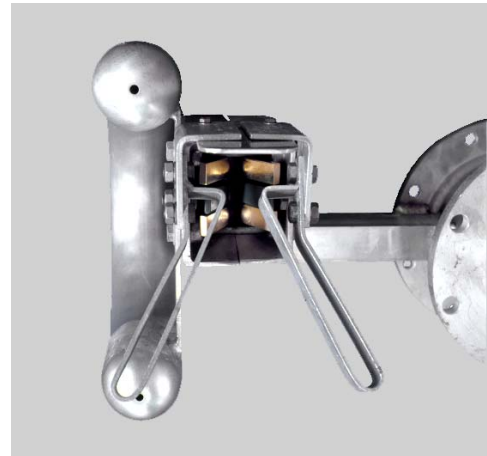

2. Top intermediate piece with earthing contact type TEB

- 31 – contact finger
- 32 – corona protection fitting

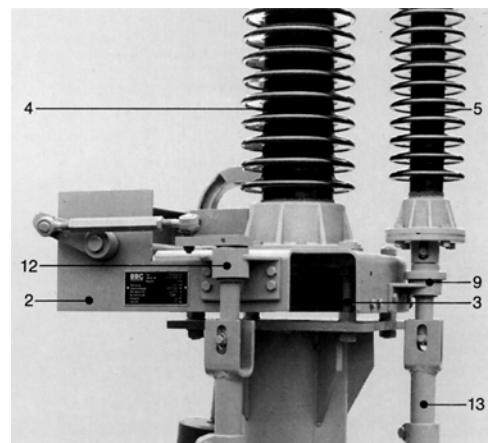

3. Pole of pantograph disconnecter TFB 245 with built in earthing switch type TEB

- 2 – base frame
- 3 – stud bolt
- 4 – support insulator; 5 – rotary insulator
- 9 – operating shaft
- 12 – pivot bearing

Design –continued

All gearbox and pantograph bearings are permanently lubricated and thus maintenance-free. Disconnectors for high short-circuit currents are equipped with a damper. This damper is mounted between the pantographs joints and is to damp the vibrations caused by the short-circuit current in the pantograph.

The suspended contact is situated above the disconnector on the overhead line and is grasped with a high pressure, when the pantograph is in closed position. Current is transferred through the pantograph joints by tapered roller contacts and further through the gearbox. These connections have been proven correct for many years operation under extreme conditions in wet and cold climate, and their operating durability is considerably higher than that of the still widely used multi-strand conductors which are more susceptible to corrosion because of their large surface area.

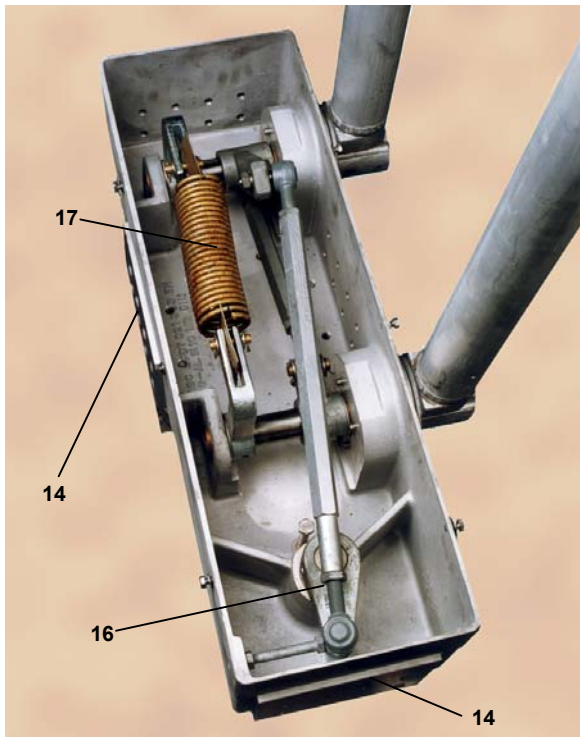

4. Gear box of TFB pantograph disconnector

- 14 - H.V.-terminals
- 16 – operating lever
- 17 – counterbalance spring

Earthing switches

The optionally available two-motion earthing switch with its pivot bearing is attached to the disconnector frame. The tubular contact arm is permanently connected with the earthed frame by means of flexible connection consisting of silver-plated copper strips. When in closed position, the earthing blade at the top of tubular contact arm lies between the contact fingers of the earthing contact, which is mounted on the intermediate piece.(Fig 2)

Disconnectors for voltage 123-145 kV are equipped with one-motion earthing switch type TEC. The tubular contact arm is permanently connected with the earthed frame by means of flexible connection. In closed position the contact fingers on the top of contact arm lies outside the contact piece, which is mounted on the intermediate piece.(Fig. 5)

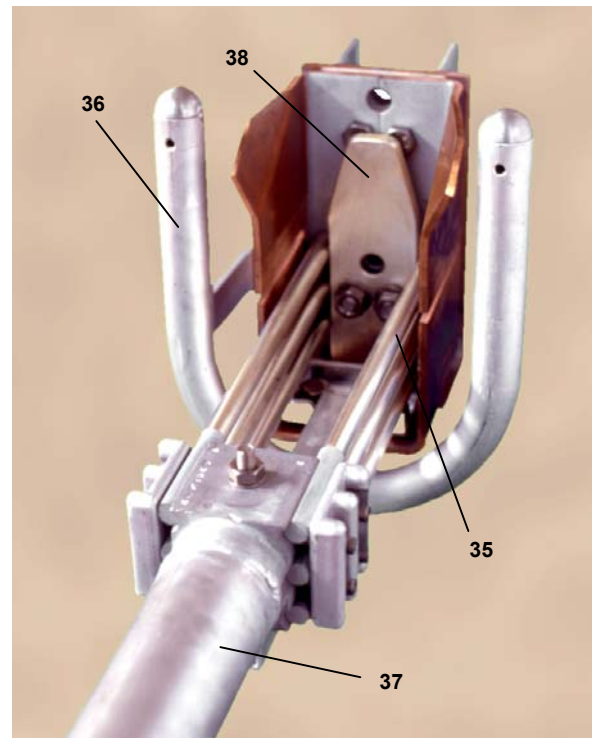

5. Earthing switch contact type TEC (without top intermediate piece)

- 35 – contact finger
- 36 – corona protection fitting
- 37—tubular contact arm
- 38 – contact piece

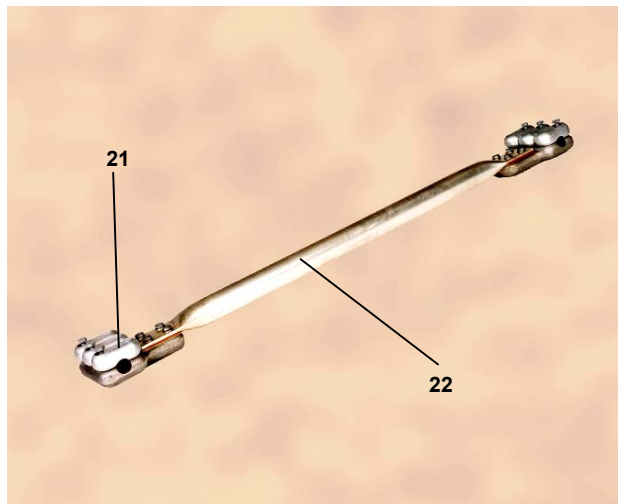

6. Suspended contact (standard design)

- 21 – contact tube
- 22 – aluminium clamp

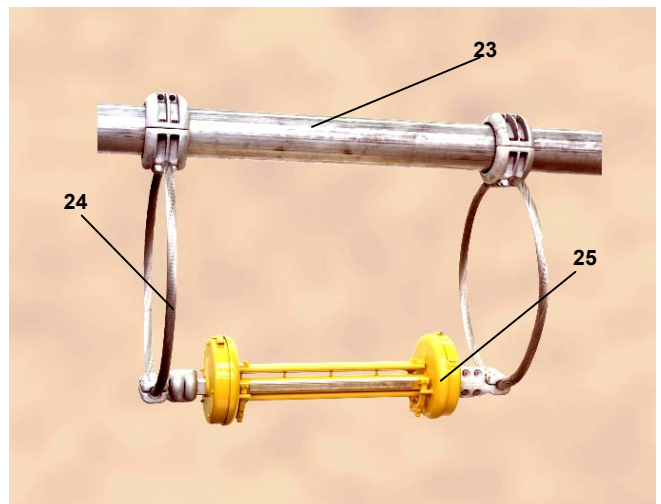

7. Suspended contact (for switching commutation currents and installation onto tube bus-bar)

- 23 – busbar tube
- 24 – conductor ring
- 25 – housing of switching chambers

Mode of Operation

Each pole of the disconnectors and earthing switches is actuated by a separate operating mechanism.

The torque from the motor of operating mechanism is transmitted through the operating shaft and rotary insulator to the top bearing in the gearbox and from there to both pantograph arms by means of operating rods.

During making or breaking, before reaching its final position the operating lever in the gearbox travels through a dead centre position, thus preventing the pantograph arms of the disconnector from opening and closing incidentally (e.g. due to breakage of the rotary insulator or to vibrations caused by an earthquake).

The contact strips on the pantograph arms during making operation travel through a wide reach angle and that guarantees reliable grasping of the suspended contact even if its position changes considerably due to the influence of adverse weather conditions (e.g. strong wind). The high contact pressure in closed position does not only assure reliable current transfer but also reduces contact wear. Due to the scissors' action when making and breaking the forces acting on the contacts of the disconnector are concentrated on a single point so that even thick layers of ice can be easily broken and removed.

The design of the disconnector prevents formation of ice block between the pantograph and gearbox.

The corona protection fittings attached to the pantograph arms also serve as a catching device in case of vertical movement of the suspended contact and thus preventing the suspended contact from slipping out of the pantograph arms.

Operating Mechanisms

All disconnectors can be supplied with manual operating mechanism or motor-operated mechanism according to the client's request. The operating mechanisms are fastened laterally below the base frame within easy reach from the ground level.

Interlocks

At the client's request the disconnector and earthing switch can be interlocked with each other so that the earthing switch can be operated only when the disconnector is in the open position and the disconnector can be operated only when the earthing switch is in the open position.

Disconnectors with motor-operated mechanism can be electrically interlocked.

As the additional interlocking facility operating mechanisms can be equipped with the blocking magnet, which prevents any operation of the manual operating mechanism or emergency manual operation of motor operated mechanism if there is no actuating signal from the control room. This enables the centralised supervision over all manual operations of disconnectors and earthing switches in the whole substations.

Little Maintenance

Disconnectors are practically maintenance-free due to the selection of the materials used and the design, for example covering of the gearbox and use of bearings with permanent lubrication. Inspections and maintenance are mainly limited to components exposed to atmospheric influences and cover for example cleaning the insulators. Under normal climatic conditions the inspection intervals are 5 years.

Characteristics

Disconnecter		TFB 123	TFB 145	TFB 170	TFB 245	TFB 300	TFB 362	TFB 420	TFB 420-1	TFB 550
Rated voltage	kV	123	145	170	245	300	362	420	420	550
Rated normal current										
type pc	A	3150	3150	3150	3150	3150	3150	3150	3150	3150
type q	A	4000	4000	4000	4000	4000	4000	4000	4000	4000
Rated peak withstand current of disconnecter and earthing switch										
type pc /q	kA	100/125	100/125	100/125/160	100/125/160	100/125/160	100/125/160	100/125/160	100/125	100/125
Rated short-time withstand current (rms.)	kA	40 / 50	40 / 50	40 / 50 / 63	40 / 50 / 63	40 / 50 / 63	40 / 50 / 63	40 / 50 / 63	40 / 50	40 / 50
Rated power-frequency withstand voltage 50 Hz, 1min										
to earth	kV	230	275	325	460	380	450	520	520	620
across open switching device	kV	265	315	375	530	435	520	610	760	800
Rated lighting impulse withstand voltage 1,2 / 50µs										
to earth	kV	550	650	750	1050	1050	1175	1425	1425	1550
across open switching device	kV	630	750	860	1200	1050(+170)*	1175(+205)*	1425(+240)*	1550(+300)*	1550(+315)*
Rated switching impulse withstand voltage 250/2500 µs										
to earth:	kV	-	-	-	-	850	950	1050	1175	1175
across open switching device	kV	-	-	-	-	700 (+245)	800(+295)	900(+345)	900(+450)	900(+450)
Discharge inception voltage	kV	>80	>95	>110	>160	>190	>230	>270	>270	>335
Radio interference voltage	µV	<1000	<1000	<1000	<1000	<1000	<1000	<1000	<1000	<1000
3- phase breaking capacity inductive / capacitive	A	2	2	2	1,5	1	1	1	1	1
Bus-transfer switching ability according to IEC62271-102 annex B**	A/V	1600/100	1600/100	1600/100	1600/200	1600/200	1600/200	1600/300	1600/300	1600/300
Inducted current switching ability acc. to IEC62271-102 annex C class A **										
for electromagnetic coupling	A/kV	50 / 0,5	50 / 1	50 / 1	80 / 1,4	80 / 1,4	80 / 2	80 / 2	80 / 2	80 / 2
for electrostatic coupling	A/kV	0,4 / 3	0,4 / 3	0,4 / 3	1,25 / 5	1,25 / 5	1,25 / 5	1,25 / 5	1,25 / 5	2 / 8
Inducted current switching ability acc. to IEC62271-102 annex C class B **										
for electromagnetic coupling	A/kV	80 / 2	80/2	80 / 2	80 / 2	160 / 10	160 / 10	160 / 10	160 / 10	160 / 20
for electrostatic coupling	A/kV	2 / 6	2 / 6	3 / 9	3 / 12	10 / 15	18 / 17	18 / 20	18 / 20	25 / 25
Insulator design:										
minimum failing load	kN	6,0-8,0-10,0	6,0-8,0-10,0	6,0-8,0-10,0	6,0-8,0-10,0	6,0-8,0-10,0	6,0-8,0-10,0	6,0-8,0-10,0-12,5	6,0-8,0-10,0-12,5	6,0-8,0-10,0-12,5
overall height	mm	1220	1500	1700	2300	2650	2650	3350	3350	4200
minimum crepage distance	mm	2460	2900	3400	4900	4900	7240	8400	8400	10500
Admissible mechanical terminal load:										
static and dynamic	kN	4,2-5,6-7,0	4,2-5,6-7,0	4,2-5,6-7,0	4,2-5,6-7,0	4,2-5,6-7,0	4,2-5,6-7,0	4,2-5,6-7,0-8,75	4,2-5,6-7,0-8,75	4,2-5,6-7,0-8,75
static portion	kN	1,5-2,0-2,5	1,5-2,0-2,5	1,5-2,0-2,5	1,5-2,0-2,5	1,5-2,0-2,5	1,5-2,0-2,5	1,5-2,0-2,5-3,15	1,5-2,0-2,5-3,15	1,5-2,0-2,5-3,15

* Values in brackets are peak values of power frequency voltage applied to the opposite terminal

** As optional extras

Main dimensions and weights

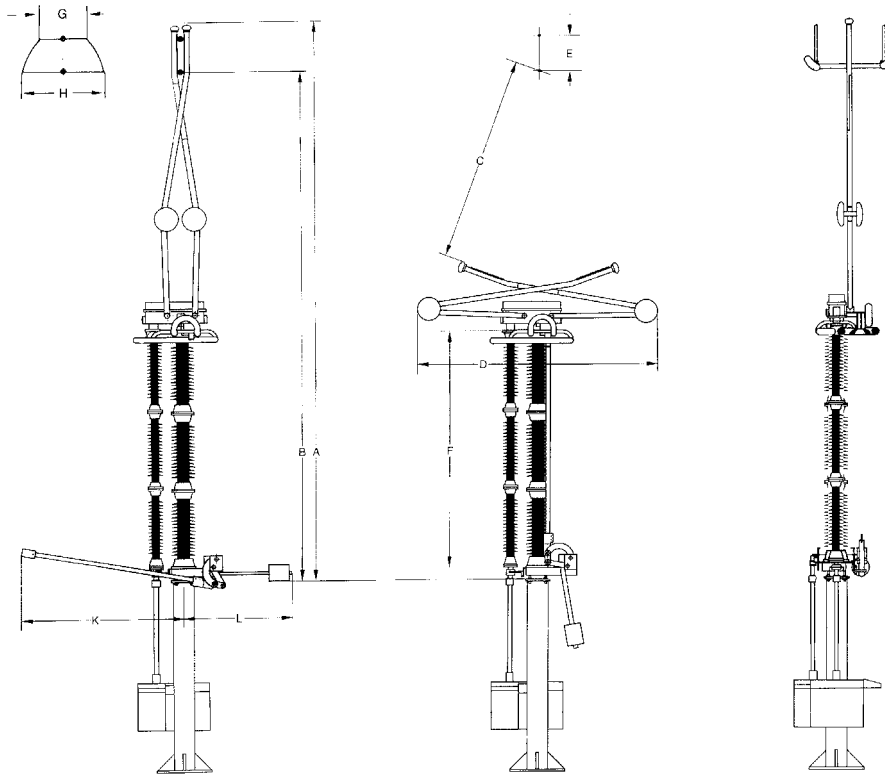

Main dimensions		TFB 123	TFB 145	TFB 170	TFB 245	TFB 300	TFB 362	TFB 420	TFB 420-1	TFB 550
Earthing switch type:		TEC	TEC	TEC	TEC	TEC	TEB	TEB	TEB	TEB
Height of disconnector (CLOSED)	mm	3930	4210	5640	6240	6590	7460	7910	8540	10610
B Distance to suspended contact	mm	3500	3780	5080	5680	6030	6900	7350	7970	9710
C Minimum isolating distance	mm	1400	1400	2300	2300	2300	2950	2950	3500	4200
D Width of disconnector (OPEN)	mm	1990	1990	2960	2960	2960	3560	3560	4160	5260
E Catching range	mm	300	300	400	400	400	400	400	400	500
F Height of insulator	mm	1220	1500	1700	2300	2650	2900	3350	3350	4000
G Envelope, top	mm	170	170	260	260	260	260	260	260	330
H Envelope, bottom	mm	580	580	840	840	840	840	840	840	950
K Earthing switch (OPEN)	mm	1100	1300	1230	1830	2180	2430	2980	2980	3730
L Earthing switch counterpoise (OPEN)	mm	-	-	-	-	-	1030	1030	1030	1030
Weights										
Disconnector 3-pole group ¹⁾²⁾	kg	890	980	1070	1340	1500	1750	1950	2100	2350
Built-on earthing switch 3-pole group	kg	80	80	80	80	80	440	440	440	440

¹⁾ Including operating mechanisms

²⁾ Including standard insulators

HAPAM

HAPAM Poland Sp. z o.o.

22/24 ks. bp. W Tymienieckiego Street
90-349 Lodz, POLAND

Tel. +48 42 663 54 50

Fax. +48 42 663 54 97

www.hapam.pl